

Product Specification

Brigade Model Number: BE-800C

Brigade Stock Code: A1623A

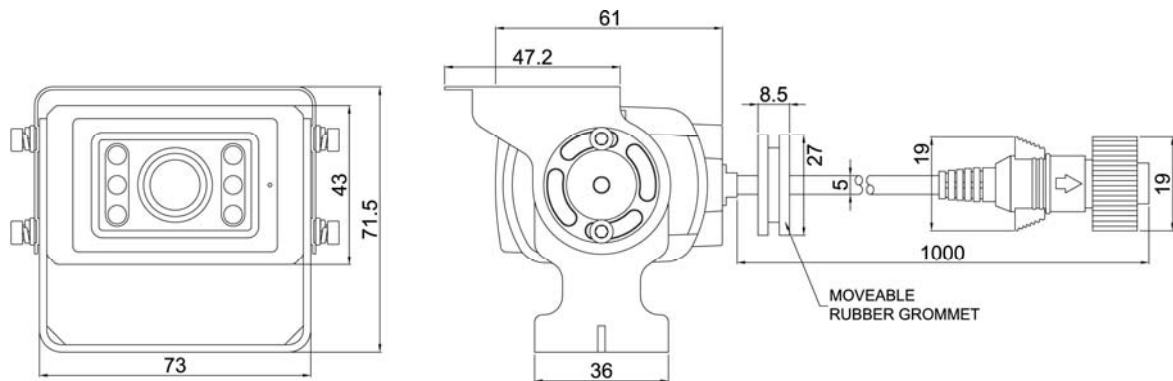

Dimensions: mm

Product Specification

Environmental Specifications:

- Shock Rating: 100 G
- Vibration Rating: 20 G
- Camera IP Rating: IP68
- Connector IP Rating: IP67
- Operating Temperature: -30° to +80°C
- Storage Temperature: -40° to +90°C

Approved Standards:

- CE
- RoHS
- WEEE
- 2006/28/EC
- 2003/97/EC with compliant monitor.
- R46 with compliant monitor.
- 95/54/EC
- ECE R10.02
- HALT
- ISO 20653: 2006 (IP Testing)

Technical Specifications:

- Operating Voltage: 12 Vdc
- Current Consumption: ≤250mA
- Power Consumption: ≤2.5 Watts
- Imaging Devices: CCD - 1/3" SONY
DSP - SONY
- TV System: PAL
- Picture Elements: 512 (H) x 582 (V)
- Visual Resolution: 380 TV Lines
- Lens Focal Length: 2.9mm
- Signal to Noise Ratio: >47dB
- Required Illumination: 0 Lux (IR LED's ON)
- Illumination Distance: 5 Meters

Technical Specifications Continued...

- Video Output: 1.0 Vp-p / 75Ω
- Viewing Angle: 104° (H), 78° (V), 130° (D)
- Weight: 400 Grams
- Length of Cable: 1 Meter
- Overall Dimensions: 88mm (W) x 79mm (D) x 71.5mm (H)
- Casing Material: Die cast Aluminium
- View: Mirror/Normal
- Finish: Black Power Coating

Features:

- Back Light Compensation
- Automatic White Balance
- Automatic IRIS
- 5x High Power Infrared LEDs
- 1x Day/Night Sensor (CDS)
- Integrated Heater (<-10°C)
- Integrated Microphone
- BE Type Connector
- High Quality SONY CCD & DSP

Package Contents:

- 1x Camera
- 1x Instruction Leaflet
- 1x Bracket
- 1x Sunshield
- 4x Bolts
- 1x 4mm Allen Key
- 4x 5mm Locking Nuts
- 4x 5mm Bolts
- 4x Self Tapping Screws
- 1x 30cm Self Vulcanizing Insulation Tape